

# Cuisinart®

INSTRUCTION AND  
RECIPE BOOKLET

Recipe  
Booklet  
Reverse Side



**Pure Indulgence Frozen Yogurt-Ice Cream & Sorbet Maker**

**ICE-30BCA**

For your safety and continued enjoyment of this product, always read the instruction book carefully before using.

IB-8/135

# IMPORTANT SAFEGUARDS

When using an electrical appliance, basic safety precautions should always be followed to reduce the risk of fire, electric shock, and/or injury, including the following:

1. **READ ALL INSTRUCTIONS BEFORE USING.**
2. To protect against risk of electric shock, do not place cord, plug, or base of appliance in water or any other liquid.
3. Close supervision is necessary when any appliance is used by or near children.
4. Always unplug from outlet when not in use, before putting on or taking off parts, and before cleaning.
5. Avoid contact with moving parts. Keep hands, hair, clothing, as well as spatulas and other utensils away during operation to reduce the risk of injury and/or damage to the appliance.
6. Do not operate any appliance with a damaged cord or plug, or after the appliance malfunctions, or is dropped or damaged in any manner. Return the appliance to the nearest Cuisinart Repair Centre for examination, repair, electrical or mechanical adjustment.
7. The use of attachments not recommended by Cuisinart may cause fire, electric shock or risk of injuries.
8. Do not use outdoors.
9. Do not let cord hang over edge of table or counter, or touch hot surfaces.
10. Keep hands and utensils out of freezer bowl while in use to reduce the risk of injury to persons or to the appliance itself. **DO NOT USE SHARP OBJECTS OR UTENSILS INSIDE THE FREEZER BOWL!** Sharp objects will scratch and damage the inside of the freezer bowl. A rubber spatula or wooden spoon may be used when the appliance is in the OFF position.
11. This appliance is for household use. Any servicing other than cleaning and user maintenance should be done only by authorised Cuisinart Repair Personnel.
12. Do not use the freezer bowl on flames, hot plates or stoves. Do not expose to heat source. Do not wash in dishwasher; doing so may cause risk of fire, electric shock or injury.

This appliance is not intended for use by persons (including children) with reduced physical, sensory or mental capabilities, or lack of experience and knowledge, unless they have been given supervision or instruction concerning use of the appliance by a person responsible for their safety.

Children should be supervised to ensure that they do not play with the appliance.

# SAVE THESE INSTRUCTIONS FOR HOUSEHOLD USE ONLY

## CAUTION

This appliance is for household use. Any servicing other than cleaning and user maintenance should be performed by an authorised service representative.

- Do not immerse base in water.
- To reduce the risk of fire or electric shock, do not disassemble the base. Note: the base does not contain any user-serviceable parts.
- Repairs should be made only by authorised personnel.
- Check voltage to be sure that the voltage indicated on the name plate agrees with your voltage.
- Never clean with scouring powders or hard implements.

## FEATURES AND BENEFITS

### 1. Ingredient Spout

Pour recipe ingredients through the spout. Also use to add ingredients, like chips or nuts, without interrupting the freezing cycle.

### 2. Easy-lock Lid

Transparent to let you watch the freezing process as it progresses. Lid is designed to easily lock to the base.

### 3. Mixing Arm

Mixes and aerates ingredients in freezer bowl to create frozen dessert or drink.

### 4. Freezer Bowl

Contains cooling liquid within a double insulated wall to create fast and even freezing. Double wall keeps the bowl cool and at an even temperature.

### 5. Base

Contains heavy-duty motor strong enough to handle ice cream, frozen yoghurt, sherbet, sorbet, and frozen drinks.

### 6. On/Off Dial

### 7. Rubber Feet (not shown)

Nonslip feet keep base stationary during use.

### 8. Cord Storage (not shown)

Unused cord is easily pushed into the base to keep counters neat and safe.

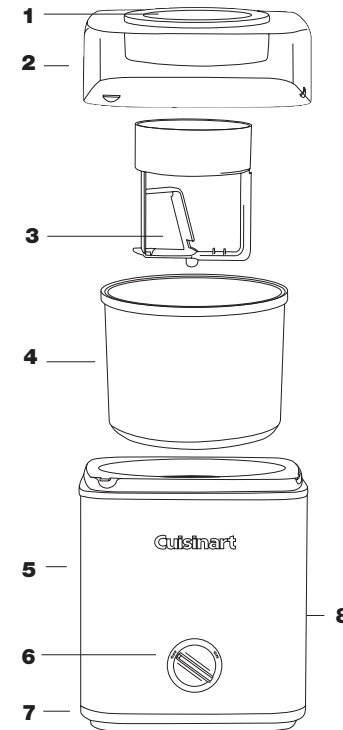

## BEFORE USING FOR THE FIRST TIME

DO NOT immerse the motor base in water. Wipe it with a moist cloth. Wash the lid, freezer bowl and mixing arm in warm soapy water to remove any dust or residue from the manufacturing and shipping process. DO NOT clean any of the parts with abrasive cleaners or hard implements.

## FREEZING TIME AND BOWL PREPARATION

The freezer bowl must be completely frozen before you begin your recipe. The length of time needed to reach the frozen state depends on how cold your freezer is. For the most convenient frozen desserts and drinks, leave your freezer bowl in the freezer at all times. You can take it out any time for immediate use. In general, freezing time is between 6 hours and 22 hours. To determine whether the bowl is completely frozen, shake it. If you do not hear liquid moving, the cooling liquid is frozen. Before freezing, wash and dry the bowl. Wrap it in a plastic bag to prevent freezer burn. We recommend that you place the freezer bowl in the back of your freezer where it is coldest.

**Reminder:** Your freezer should be set to  $-18^{\circ}\text{C}$  to ensure proper freezing of all foods.

## MAKING FROZEN DESSERTS OR DRINKS

1. Use Cuisinart's recipes from the pages that follow, or use your own recipe, making sure it yields 2 litres or less. Do not fill the freezer bowl higher than 1.2 cm from the top. The ingredients will increase in volume during the freezing process. For best results, prepare ingredients in a container from which it is easy to pour.
2. Remove the freezer bowl from the freezer. (Remove plastic bag if you have wrapped freezer bowl.) Place freezer bowl on the centre of the base.  
**NOTE:** Bowl will begin to defrost quickly once it has been removed from freezer. Use it immediately after removing from freezer.
3. Place mixing arm in freezer bowl. Arm does not fit tightly. It just rests in the centre of the bowl, with the circle side facing up.
4. Place lid on base. Easy-lock lid mechanism allows lid to rest on base in multiple positions (see diagram).

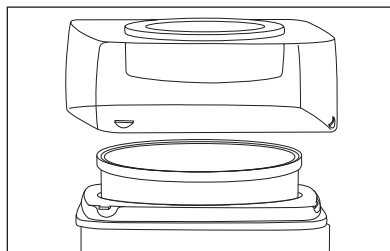

5. Turn the On/Off switch to ON position. Freezer bowl will begin to turn.
6. Immediately pour ingredients through ingredient spout.
7. Frozen desserts or drinks will be done in 25–35 minutes. The time will depend on the recipe and volume of the dessert or drink you are making. When the mixture has thickened to your liking, it is done. If you desire a firmer consistency, transfer the dessert or drink to an airtight container and store in the freezer for two or more hours.

**NOTE:** Do not store frozen desserts or drinks in the freezer bowl. Desserts and drinks will stick to the side of the freezer bowl and may damage the bowl. Store only in a plastic airtight container.

## ADDING INGREDIENTS

Ingredients such as chips and nuts should be added about 5 minutes before the recipe is complete. Once the dessert or drink has begun to thicken, add the ingredients through the ingredient spout. Nuts and other ingredients should be no larger than a chocolate chip.

## SAFETY FEATURE

The Cuisinart® Pure Indulgence Frozen Yoghurt-Ice Cream & Sorbet Maker is equipped with a safety feature that automatically stops the unit if the motor overheats. This may occur if the dessert or drink is extremely thick, if the unit has been running for an excessively long period of time, or if added ingredients (nuts, etc.) are in extremely large pieces. To reset the unit, turn the ON/OFF switch to the OFF position. Let the unit cool off. After a few minutes, you may turn the unit on again and continue making the dessert or drink.

## CLEANING AND STORAGE

### Cleaning

Clean the freezer bowl, mixing arm and lid in warm soapy water. DO NOT PUT FREEZER BOWL IN THE DISHWASHER. DO NOT CLEAN WITH ABRASIVE CLEANSERS OR IMPLEMENTS. Wipe motor base clean with damp cloth. Dry all parts thoroughly.

### Storage

DO NOT put freezer bowl in freezer if bowl is wet. DO NOT store lid, mixing arm, or base in freezer. You may store the freezer bowl in the freezer for convenient, immediate use. Before freezing, wrap the bowl in a plastic bag to prevent freezer burn. Do not store frozen desserts or drinks in the freezer bowl in the freezer for more than 30 minutes at a time. Transfer frozen desserts or drinks to an airtight container for longer storage in the freezer.

# WARRANTY

## LIMITED THREE-YEAR WARRANTY

This warranty supersedes all previous warranties on the Cuisinart® Pure Indulgence Frozen Yoghurt-Ice Cream & Sorbet Maker.

This warranty is available to consumers only. You are a consumer if you own a Cuisinart® Pure Indulgence Frozen Yoghurt-Ice Cream & Sorbet Maker that was purchased at retail for personal, family or household use. Except as otherwise required under applicable state law, this warranty is not available to retailers or other commercial purchasers or owners.

We warrant that your Cuisinart® Pure Indulgence Frozen Yoghurt-Ice Cream & Sorbet Maker will be free of defects in material or workmanship under normal home use for three years from the date of original purchase.

We suggest that you complete and return the enclosed product registration card promptly to facilitate verification of the date of original purchase. However, return of the product registration is not a condition of these warranties.

If your Cuisinart® Pure Indulgence Frozen Yoghurt-Ice Cream & Sorbet Maker should prove to be defective within the warranty period, we will repair it, or if we think necessary, replace it. To obtain warranty service, please call our Consumer Service Centre toll-free at 1800 808 971 (AUST) or 0800 435 000 (NZ) or write to:

**Cuisinart Australia**

24 Salisbury Road  
Asquith NSW 2077

or

**Cuisinart New Zealand**

44 Apollo Drive  
Mairangi Bay  
Auckland New Zealand

Please also be sure to include a return address, description of the product defect, product serial number, and any other information pertinent to the product's return.

NOTE: For added protection and secure handling of any Cuisinart® product that is being returned, we recommend you use a traceable, insured delivery service. Cuisinart cannot be held responsible for in-transit damage or for packages that are not delivered to us. Lost and/or damaged products are not covered under warranty.

Your Cuisinart® Pure Indulgence Frozen Yoghurt-Ice Cream & Sorbet Maker has been manufactured to strict specifications and has been designed for use with the Cuisinart® Pure Indulgence Frozen Yoghurt-Ice Cream & Sorbet Maker accessories and replacement parts. These warranties expressly exclude any defects or damages caused by accessories, replacement parts or repair service other than those that have been authorised by Cuisinart®.

These warranties do not cover any damage caused by accident, misuse, shipment or other than ordinary household use.

**These warranties exclude all incidental or consequential damages.**

### BEFORE RETURNING YOUR CUISINART® PRODUCT

Important: If the nonconforming product is to be serviced by someone other than Cuisinart's Authorised Service Centre, please remind the servicer to call our Consumer Service Centre to ensure that the problem is properly diagnosed, the product serviced with the correct parts, and to ensure that the product is still under warranty.

©2008 Cuisinart  
Cuisinart® is a registered trademark of Cuisinart, 150 Milford Road,  
East Windsor, NJ 08520

Printed in China  
www.cuisinart.com  
06CU26300

S&H1618/08